

SALES DRAWING

SALES DRAWING

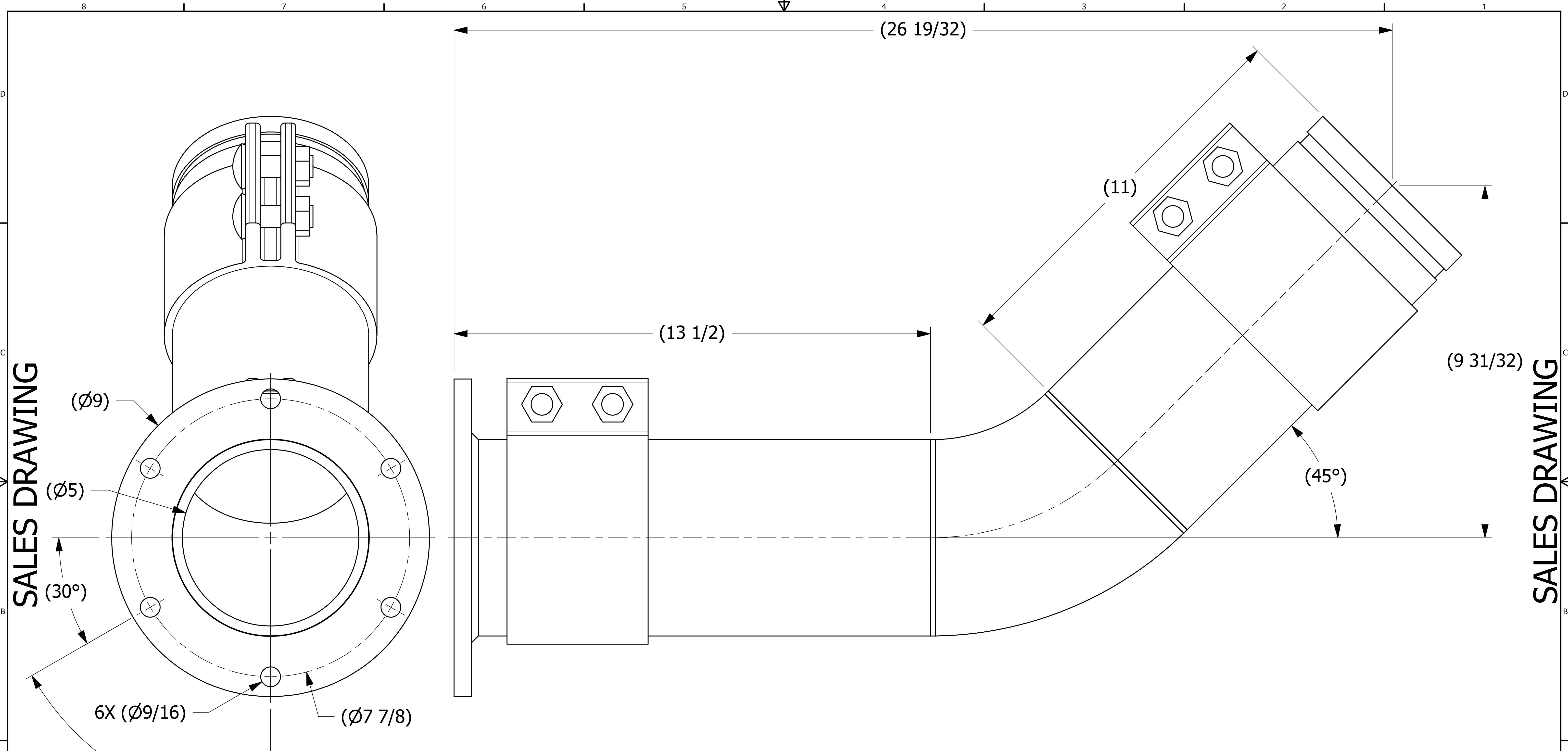

- NOTES:
 1. GASKET MATERIAL IS WHITE NEOPRENE.
 2. PIPES ARE TO BE CUT TO LENGTH.

UNLESS OTHERWISE SPECIFIED DIMENSIONAL TOLERANCES FRACTIONAL: $\pm 1/16$ X.XX: $\pm .03$ X.XXX: $\pm .015$ ANGULAR: $\pm 1^\circ$ DEBURR ALL SHARP EDGES. ALL MACHINED SURFACES TO HAVE A 125 RMS FINISH UNLESS NOTED OTHERWISE. THIRD ANGLE PROJECTION	DRAWN BY:	ACC
	CHECKED BY:	
	PROTOTYPE BY:	ACC
	PROTOTYPE DATE:	9/19/2014
	APPROVED FOR PRODUCTION BY:	ACC
	PRODUCTION DATE:	9/18/2001

A	ACC	1-17-02	REDESIGN, ADDED COMPRESSION COUPLINGS
REV	BY	DATE	DESCRIPTION
PART NAME: PD PIPE ASSEMBLY 5"X45°			
MATERIAL: ALUMINUM			
PROJECT #:	010910	SHEET #:	1 OF 1
DRAWING #:	D16185	PART #:	PD5APB01
			SCALE: 1:1

THIS PRINT, PROPERTY OF SALCO PRODUCTS INC. CONTAINS PROPRIETARY INFORMATION AND MUST NOT BE COPIED, REPRODUCED, OR USED DETRIMENTALLY TO OUR INTEREST.